

308-312
LODGE CAUSEWAY

S.M. GAUGE

Tel: +44 (0) 117 965 4615
Fax: +44 (0) 117 958 3660

BRISTOL
BS16 3RD

C O M P A N Y

Email: info@smgauge.co.uk
Web: www.smgauge.co.uk

INSTRUCTION MANUAL

PNEUMATIC HAND PUMP MODEL PHP







INDEX

S.NO	CONTENTS		PAGE NO
1	BEFORE YOU START		3
	1.1	SYMBOLS USED	3
2	INTRODUCTION		4
	2.1	SAFETY INSTRUCTIONS	5
	2.2	TECHNICAL SPECIFICATIONS	6
	2.3	ACCESSORIES	6
3	PUMP ASSEMBLY		7
	3.1	IDENTIFICATION OF PARTS	8
4	OPERATING PROCEDURE		9

1.0 BEFORE YOU START:

1.1 SYMBOLS USED:

The following are the symbols used throughout the manual.

S.NO	SYMBOL	DESCRIPTION
1		<p>Read the user manual before operating the instrument.</p>
2		<p>Warning- conditions that may pose hazards to the user.</p>
4		<p>Caution-conditions that may damage the instrument.</p>
5		<p>Special Information</p>

2.0 INTRODUCTION:

PHP hand pump is a pneumatic pressure/vacuum generating unit which is specially designed for testing and calibrating pressure instruments. This pump is manufactured with high quality for calibrating analog gauges by comparison measurements. It can be used for lab and field applications.

There is a pressure/vacuum changeover switch in the pump, which is used for selecting either vacuum or pressure output. It is fitted with a fine adjustment valve and release valve. The output pressure/vacuum of the hand pump can be adjusted precisely by the fine adjustment valve while calibration. Release valve is used for releasing the pressure/vacuum after calibration. The output pressure/vacuum of the pump is in the range of -0.90 -25/40 bar depending upon the model.

CERTIFICATION:

SM Gauge Co. Certifies that this pump is a quality product and meets its intended use and satisfies the published specifications at the time of shipment.

TECHNICAL ASSISTANCE:

Please contact SM Gauge Co. if you require any technical assistance.

WARRANTY:

One Year warranty

This warranty only covers manufacturing defects and becomes invalid if the pump is subjected to unauthorized intervention and / or use.

2.1 SAFETY INSTRUCTIONS:



- Check for system fittings and connections tight and leak free.
- Tighten the pressure release valve fully to ensure good sealing.
- 70% of the pressure/vacuum is to be given using handle and the remaining 30% is to be given using fine adjustment valve.
- Do not attempt to over tighten the other fittings to the pump as this could lead to damage of sealed joints.
- Release pressure/vacuum before changing the mode by pressure/vacuum selector.
- Do not connect Pump to external pressure source.



- The connections to the hand held test system are sealed with 'O' ring, bonded seals & Nylon washer to avoid leak.
- Ensure that the adapters are tightened sufficiently.
- Allow the pressure to settle for 1-2 minutes before taking the reading due to thermodynamic effects, setting of seals and expansion of flexible hose.

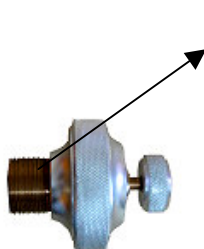

Red indicator

The fine adjustment valve should not be forced to move beyond the red line indicator on the body.

2.2 TECHNICAL SPECIFICATIONS:

- Pressure Medium : Air
- Working Pressure : - 0.90 to 10/20/25/35/40 bar
- Vernier-Adjuster : Micro-adjustable, Volume control
- Minimum Resolution of vernier: 1 mbar.
- Outlet Port : 3/8" BSP(F) /1/4" (F) BSP (Swivel) threads
- Weight : 750 grams (approx)
- Stabilization time : 1-2 minutes
- Dimension : 230mm×65mm×130mm (l×b×w)

2.3 ACCESSORIES:

STANDARD:

- (i) Hose – 1 meter with swivel Adaptor (1/4" BSP (F))
- (ii) Plastic caps (2) for dust protection
- (iii) Seal Kit. It consists of:
 - (i) Nylon Washer – 3/8" (F) (3nos).
 - (ii) Nylon Washer - 1/4" (F) (3nos).

1. ADAPTORS

1. 1/4" BSP (M) to 1/8" BSP parallel (F)
4. 1/4" BSP (M) to 3/8" BSP parallel (F)
6. 1/4" BSP (M) to 1/2" BSP parallel (F)

2. Suitable Bonded seals and Nylon washer for the above adaptors.

3.0 PUMP ASSEMBLY:

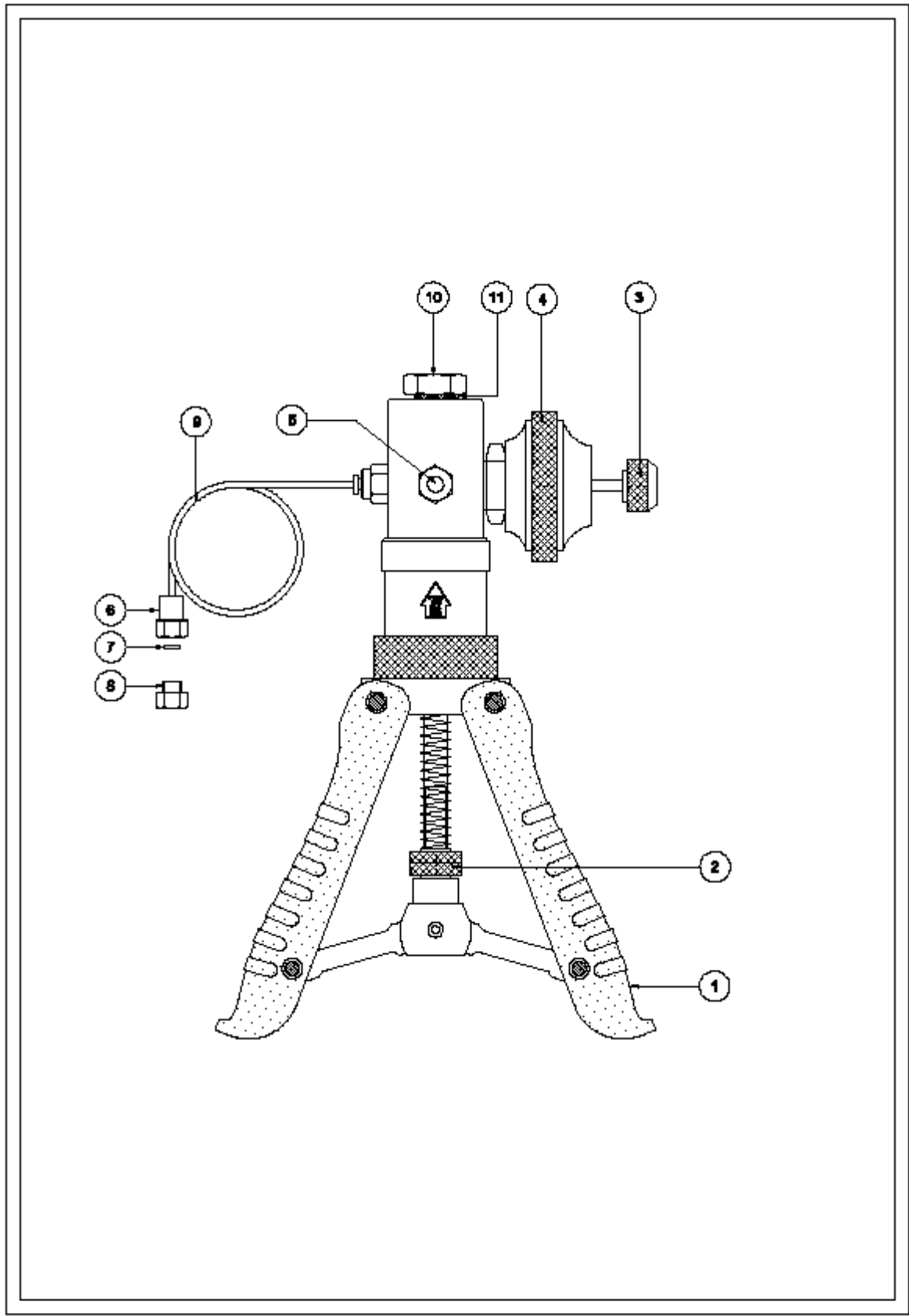

3.1 IDENTIFICATION OF PARTS:

1. Pump Handles
2. Knurling thumb nut.
3. Pressure release valve.
4. Fine adjustment valve.
5. Pressure / Vacuum selector
6. quick-fit' connectors.1/8" BSP female.
7. Nylon Washer 1/4"
8. Plastic Plug.
9. Flexible3 hose to item under test.
10. Pressure port – 3/8" BSP female connection to connect master instruments
11. Nylon Washer 3/8"

FUNCTIONAL DESCRIPTION:

PRESSURE RELEASE VALVE (3):

This can be used to reduce or release the pressure in the system. Minimal force is required to seal the system.

FINE ADJUSTMENT VALVE (4):

The pressure generated can be finely adjusted by turning the fine adjustment valve (4) either clockwise or anticlockwise to increase or decrease pressure accordingly.

PRESSURE/VACUUM SELECTOR (5):

Press the selector (5) as indicated on the label to engage the desired mode. Ensure that the release valve (3) is closed firmly (clockwise motion) prior to pumping.

KNURLING THUMB NUT (2) (OVER PRESSURE PROTECTION):

To adjust the maximum output pressure of the system turns the Knurling thumb nuts (2) to increase or decrease the stroke length so that the pressure is controlled.

4.0 OPERATING PROCEDURE:

- Connect the Master/Test instrument using the appropriate adapter and seals to the pressure port at the end of the flexible hose (6) or directly to the body (10) using appropriate adaptor.
- Open the fine adjustment valve (4) in anticlockwise direction until red mark appears.
- Ensure the Pressure release valve (3) needle tightened in clock wise direction.
- Pressure/vacuum calibration can be selected by Pressure/Vacuum selector (5).
- Generate pressure/vacuum by squeezing handles (1) together. Ensure that the handles are fully squeezed together on each stroke to achieve maximum pressure/Vacuum output.
- The output pressure/vacuum can be adjusted with the fine adjustment valve (4) for a precise pressure/vacuum adjustment.
- After the calibration, completely release the pressure/vacuum by twist off the vent-valve (Release Valve) gradually in anticlockwise direction.
- Take out the master and the test instrument from the pump.